

PRZYKŁAD



STEPCRAFT.

Instrukcja Montażu. /
Manual Montażowy.

Seria D(D.420 / D.600 / D.840)

05/22



1.3

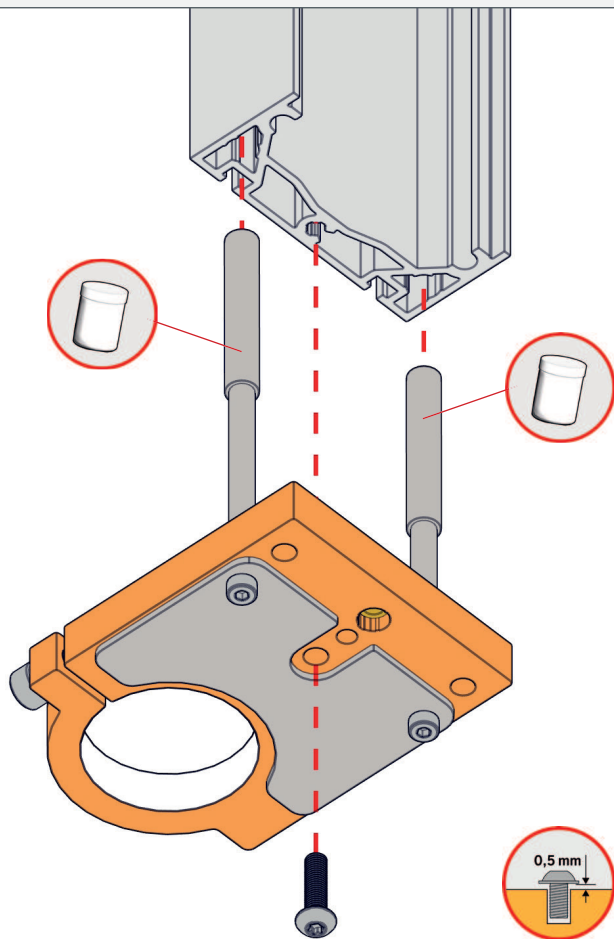

12

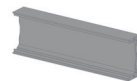

1x

75



M5 x 20

1x

0,5 mm

1.4

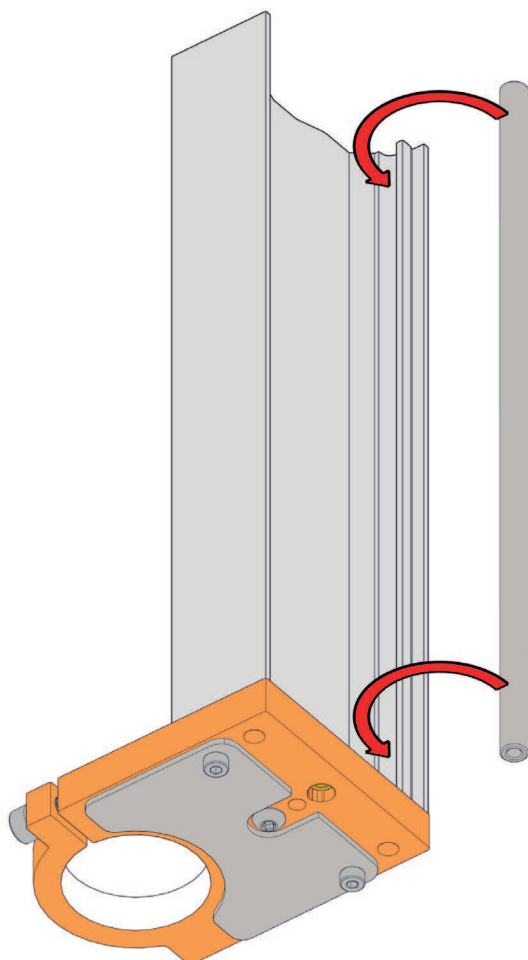

15



1x



Bauabschnitt [5.0] – Zamontuj oś X na ramie
Assembly Step [5.0] – Montuj oś X na ramie

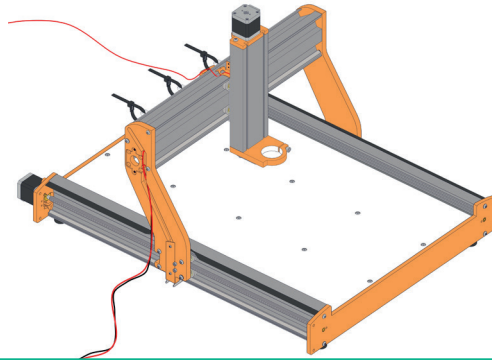

5.1

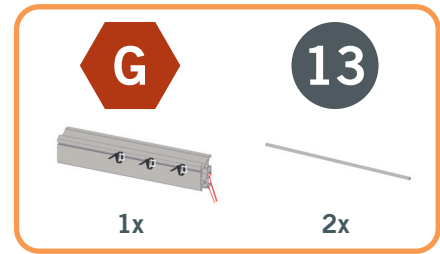
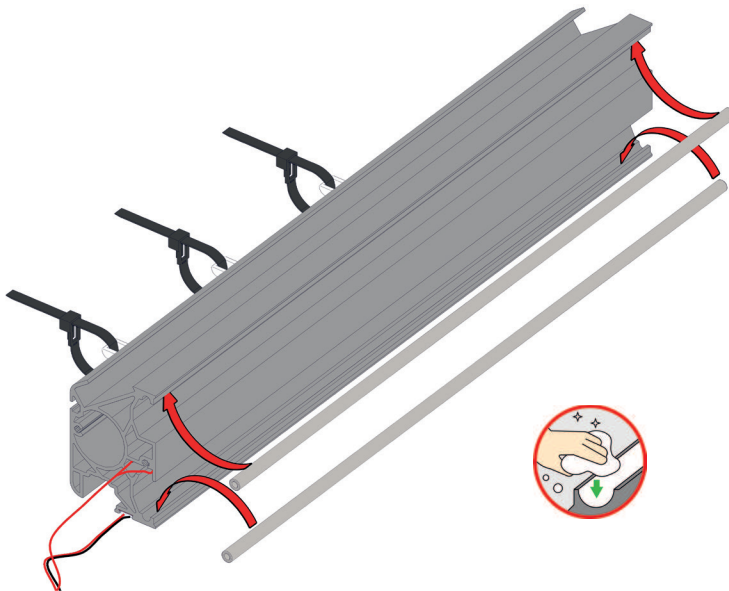

5.2

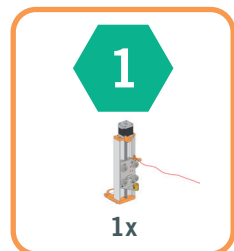
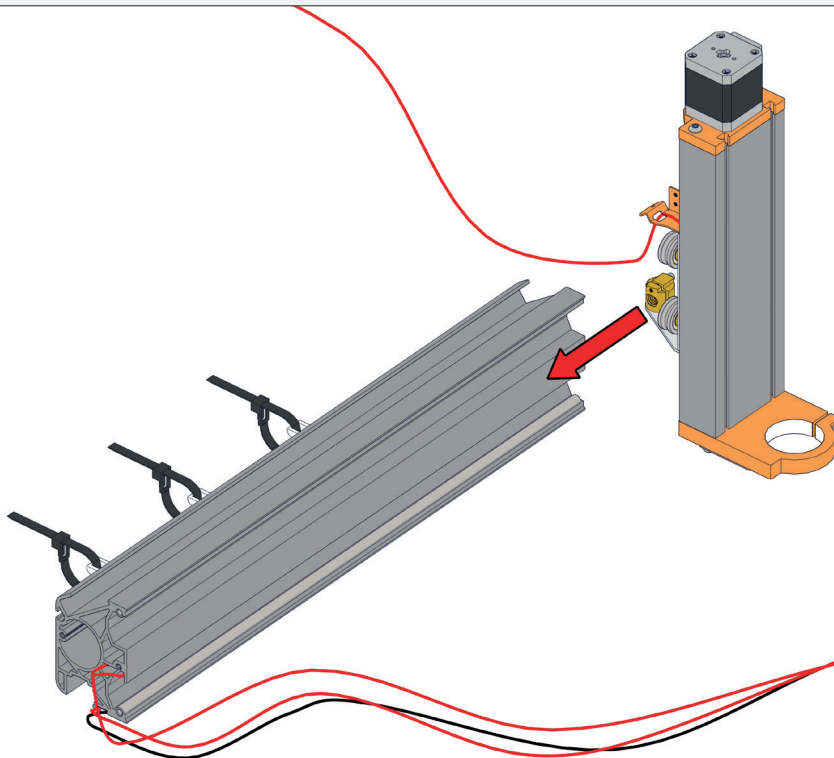

Bauabschnitt [7.0] – Włóż śrubę prowadzącą X
Assembly Step [7.0] – Włóż śrubę prowadzącą X

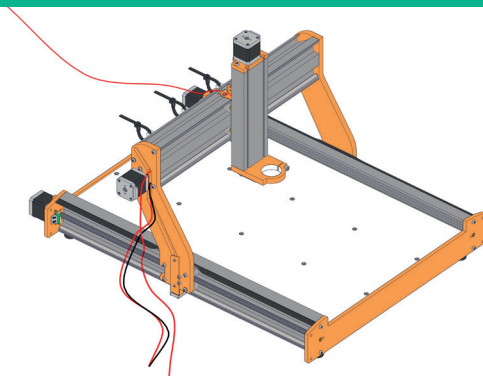

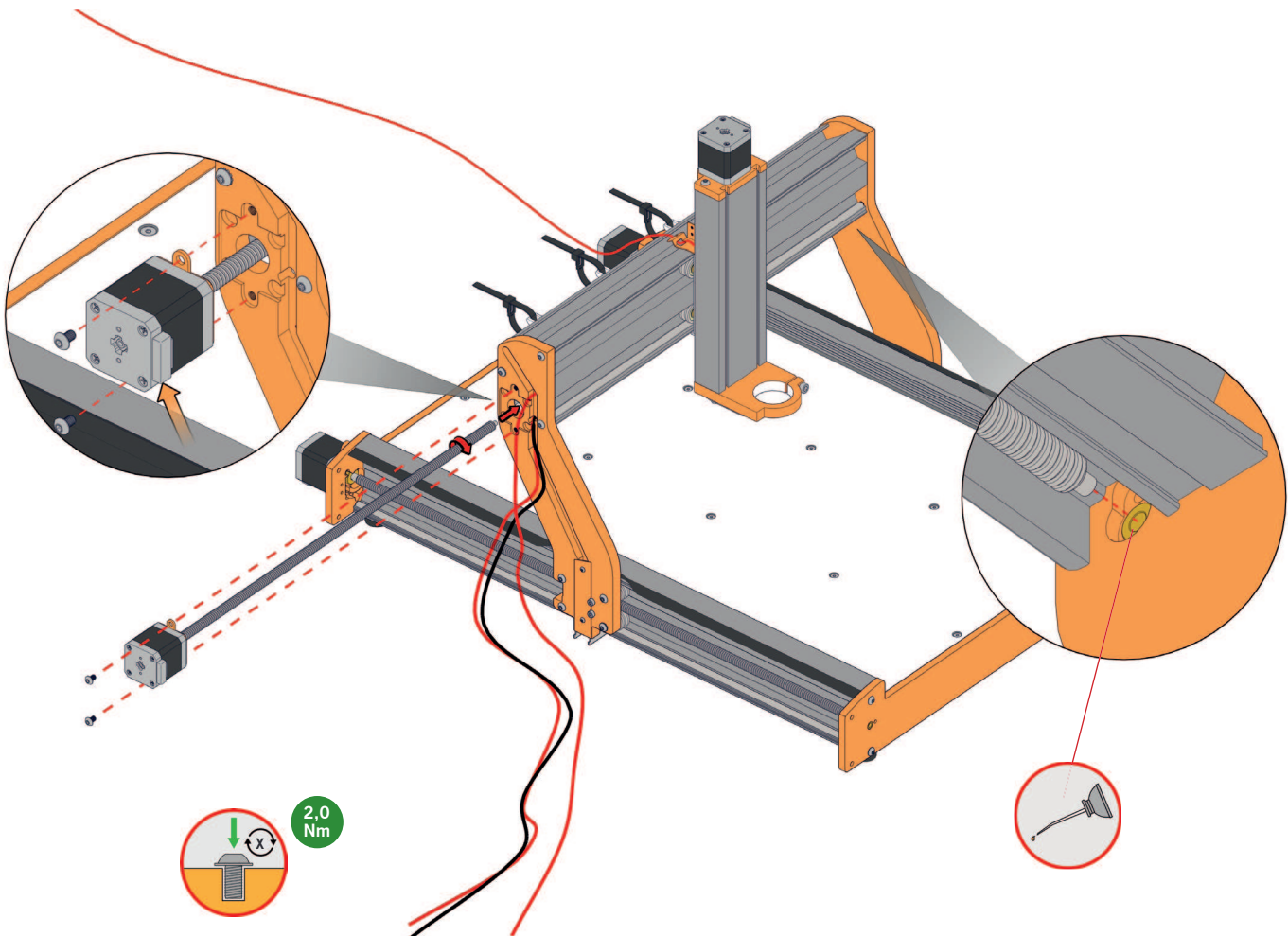
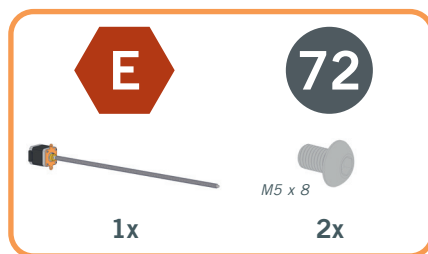

7.1



8.3

i
Nakrętka mocująca łańcucha przesuwne
można łatwo umieścić w łańcuchu przesuwnym
za pomocą klucza imbusowego 2 mm.
*The drag chain retaining nut can be placed easily
into the drag chain by using a 2 mm Allen key.*

49	44
	
1x	1x

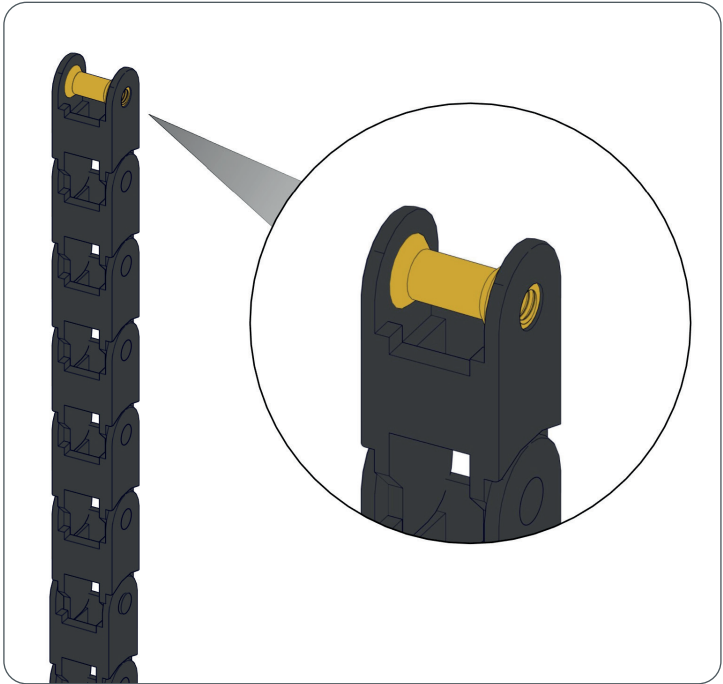
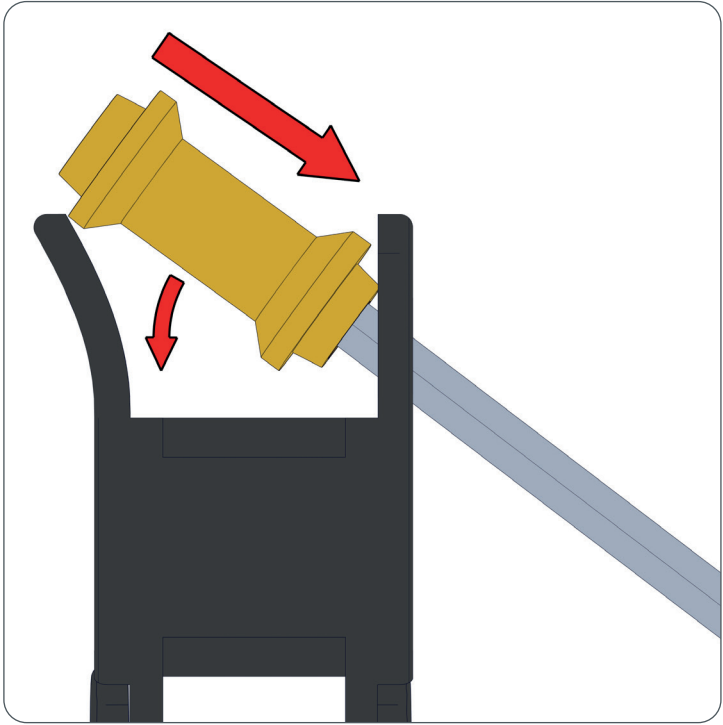
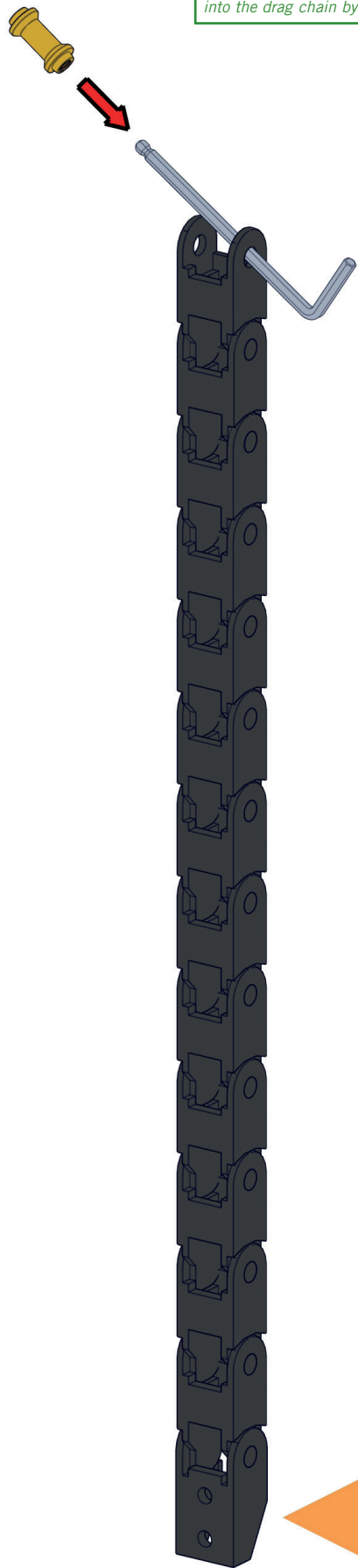

8.6

69

M3 x 5

3x

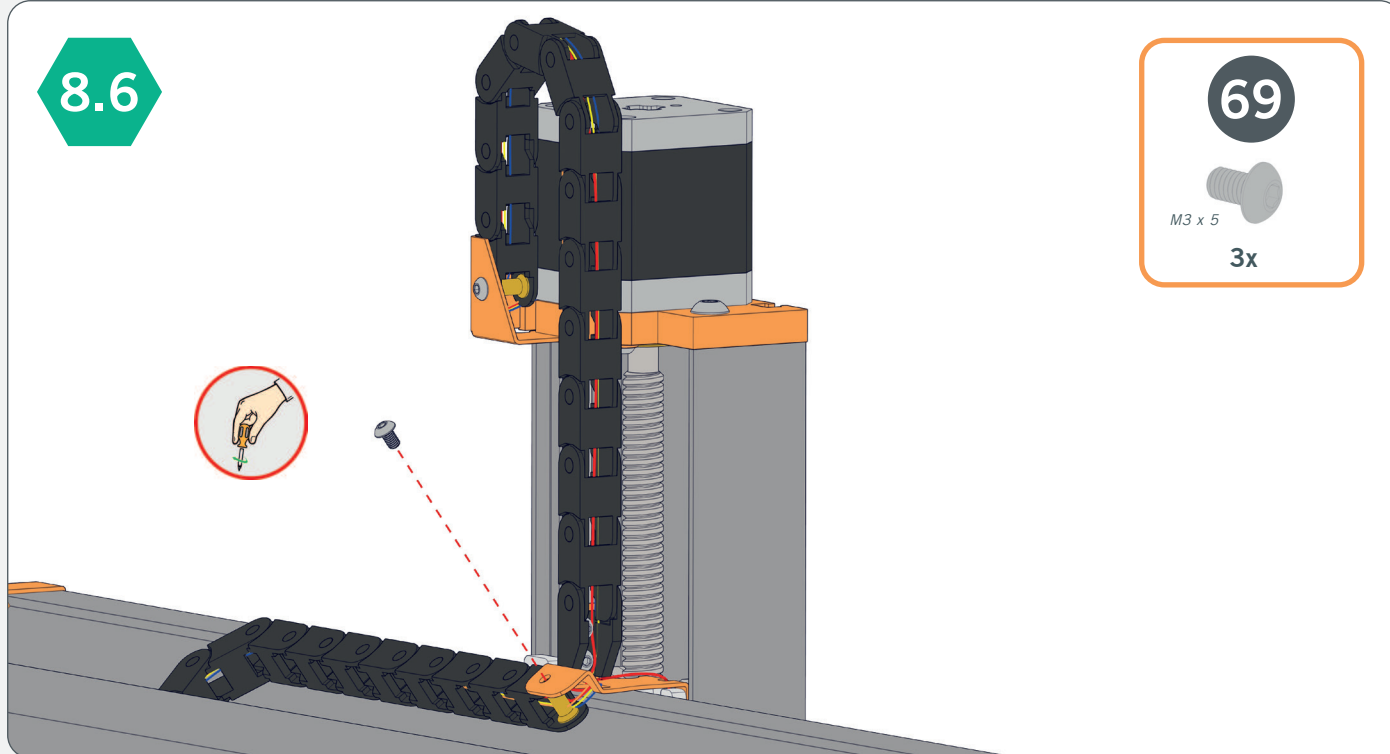

8.7

32

70

M3 x 12

1x

2x

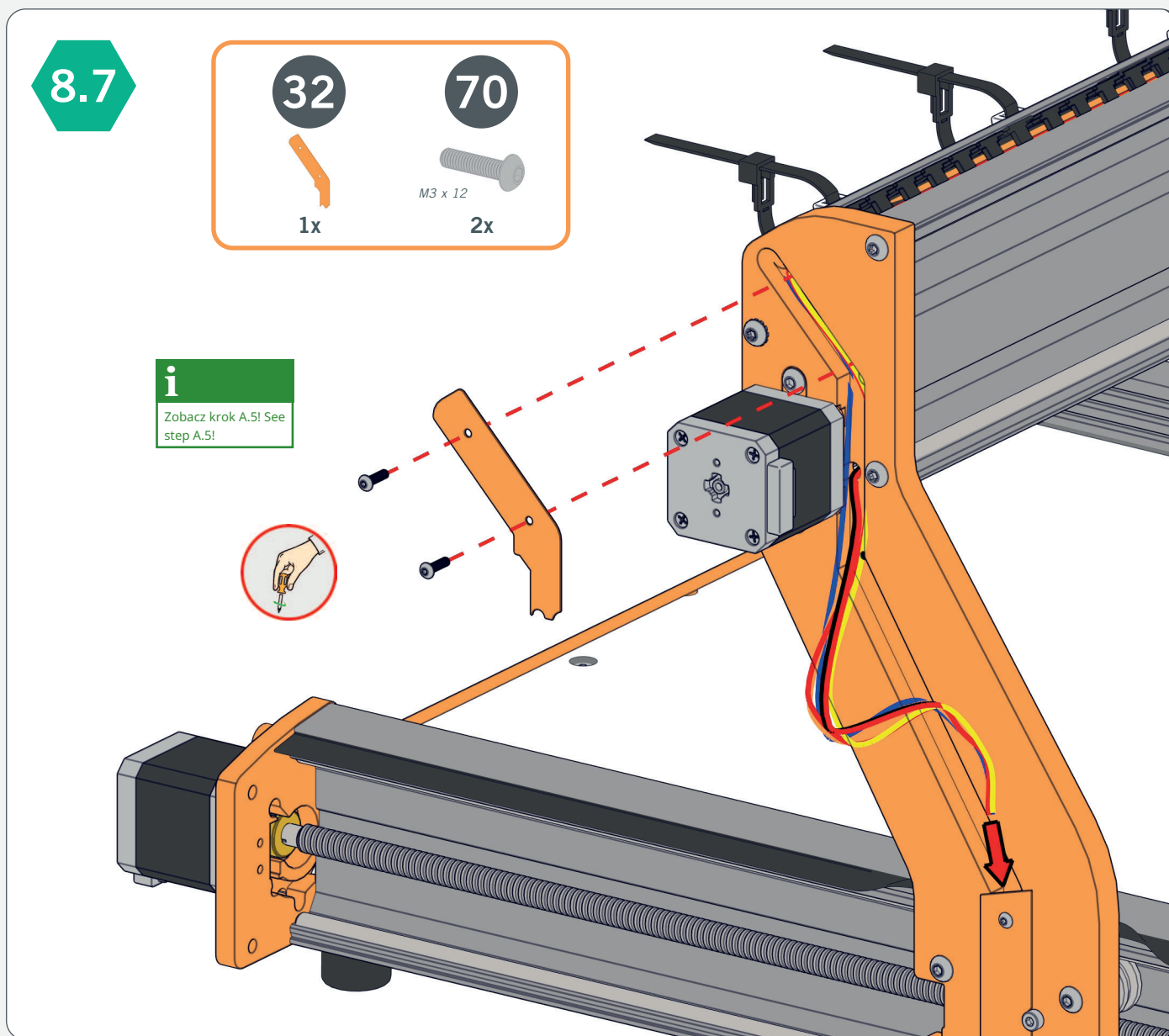

i

Zobacz krok A.5! See step A.5!

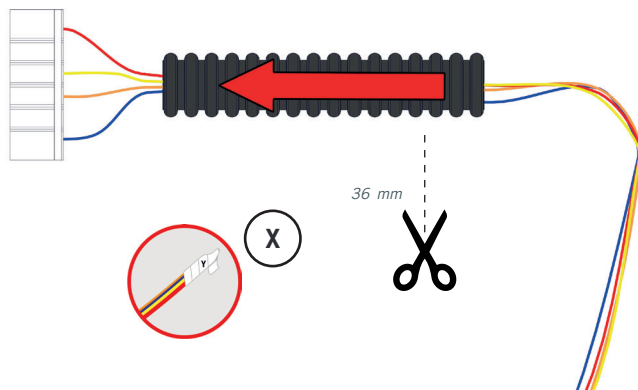

8.8



53	94
	
1x	1x

D.420 - 2050 mm
D.600 - 2050 mm
D.840 - 2400 mm

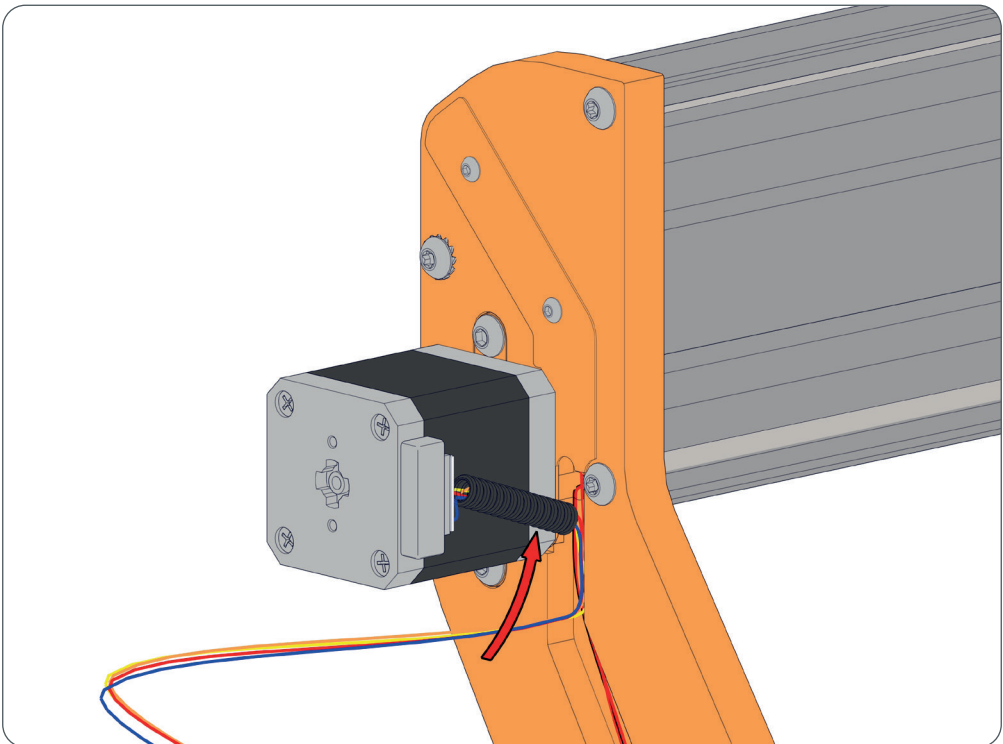
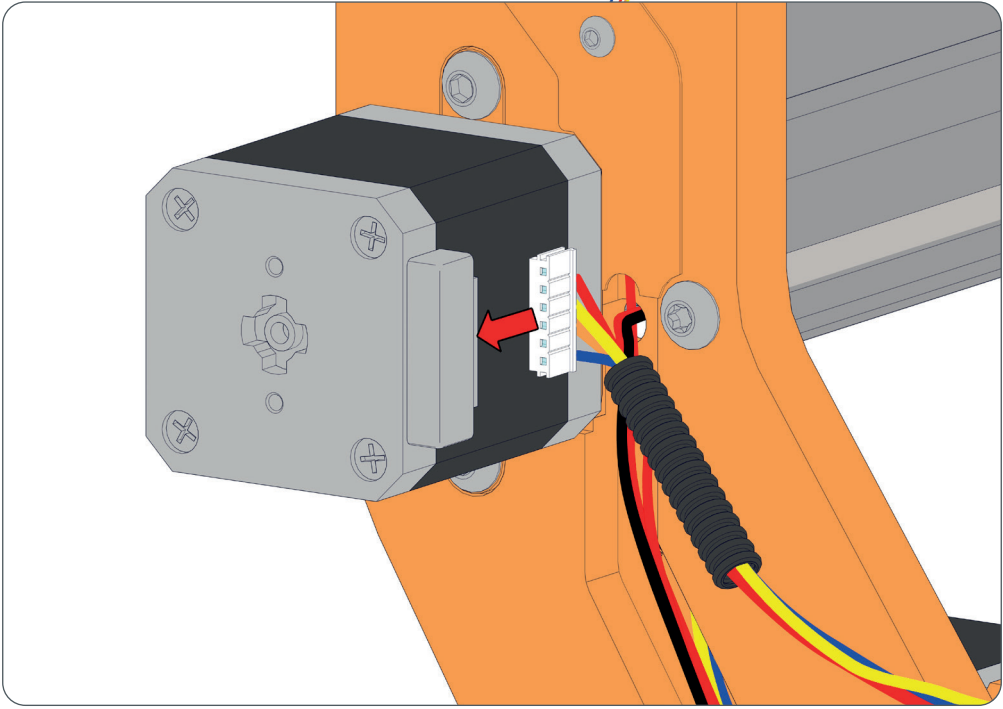

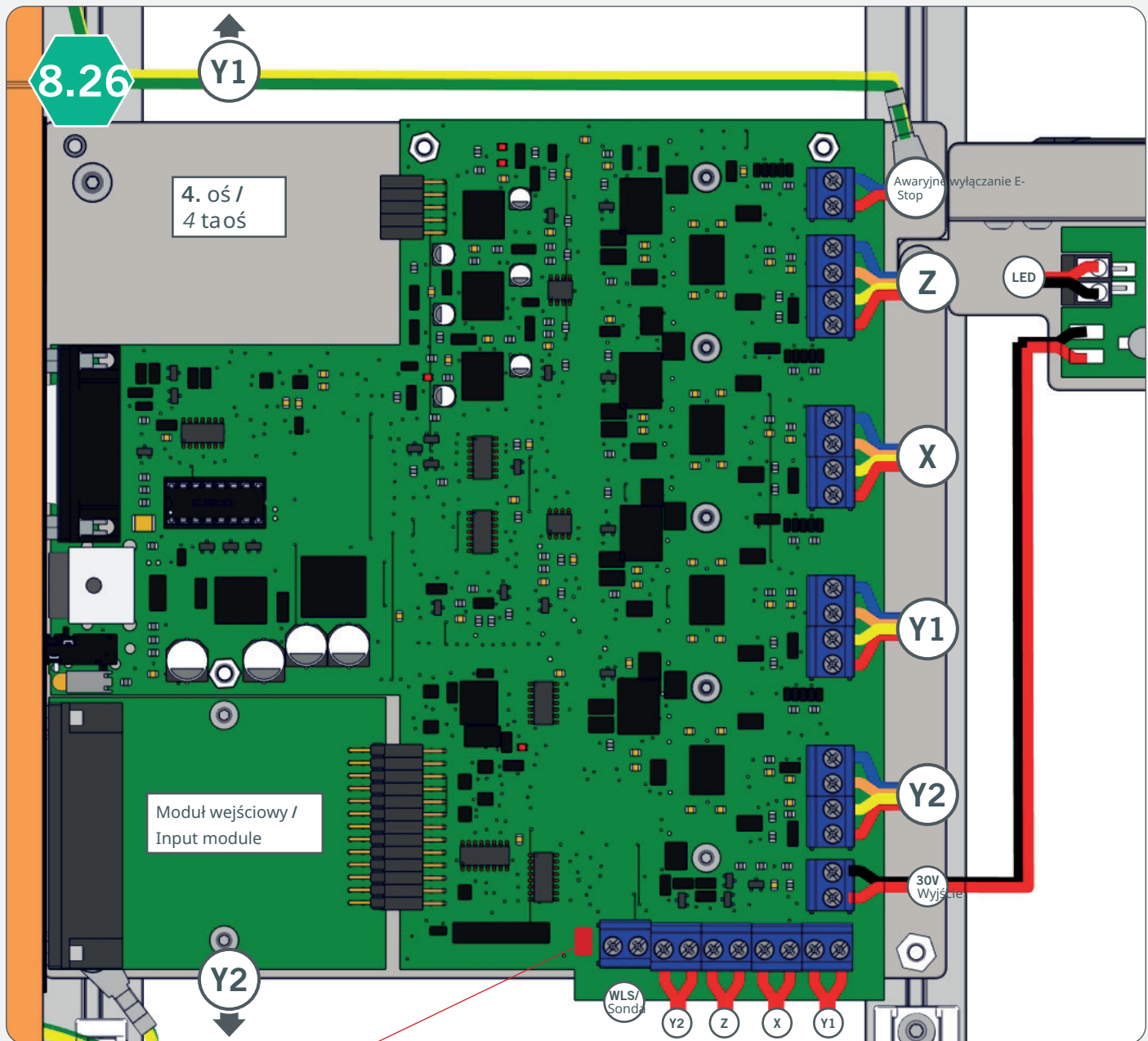

i
Aby podłączyć czujnik długości narzędzia, proszę usunąć zworkę!

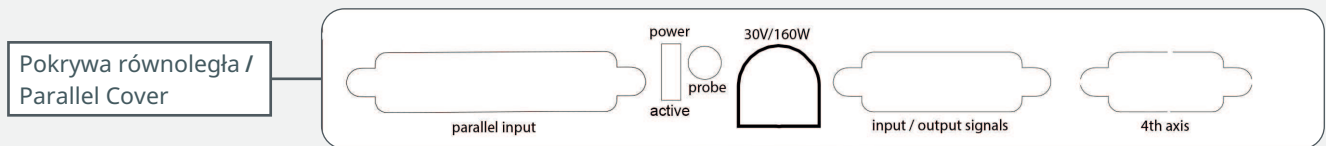
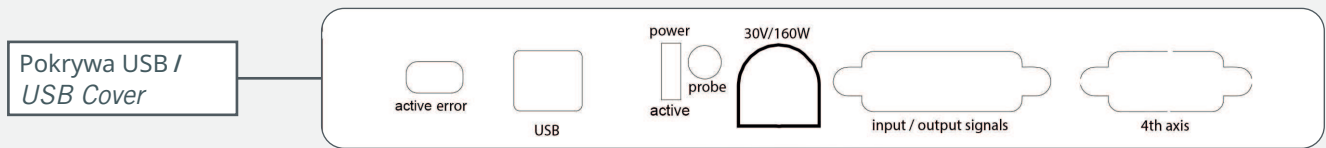
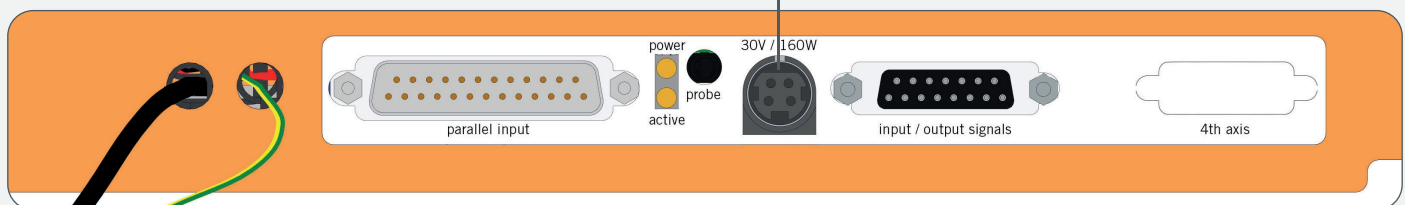
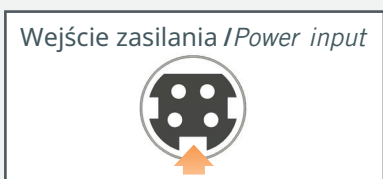

8.28

39 1x
69 4x
M3 x 5

This block contains a parts list for step 8.28. It shows a grey plastic bracket labeled '39' with a quantity of '1x' and a grey screw labeled '69' with a quantity of '4x'. The screw is specified as 'M3 x 5'.

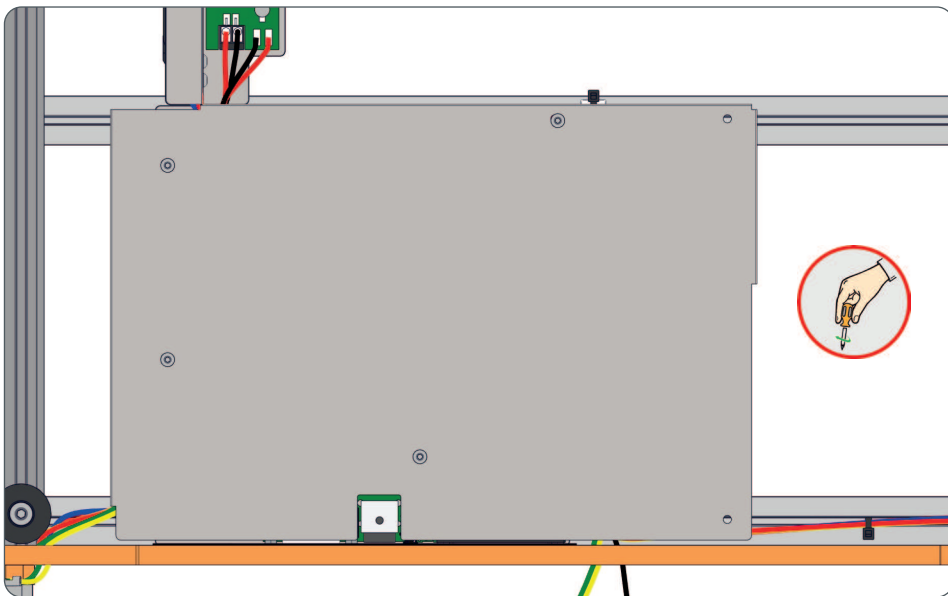
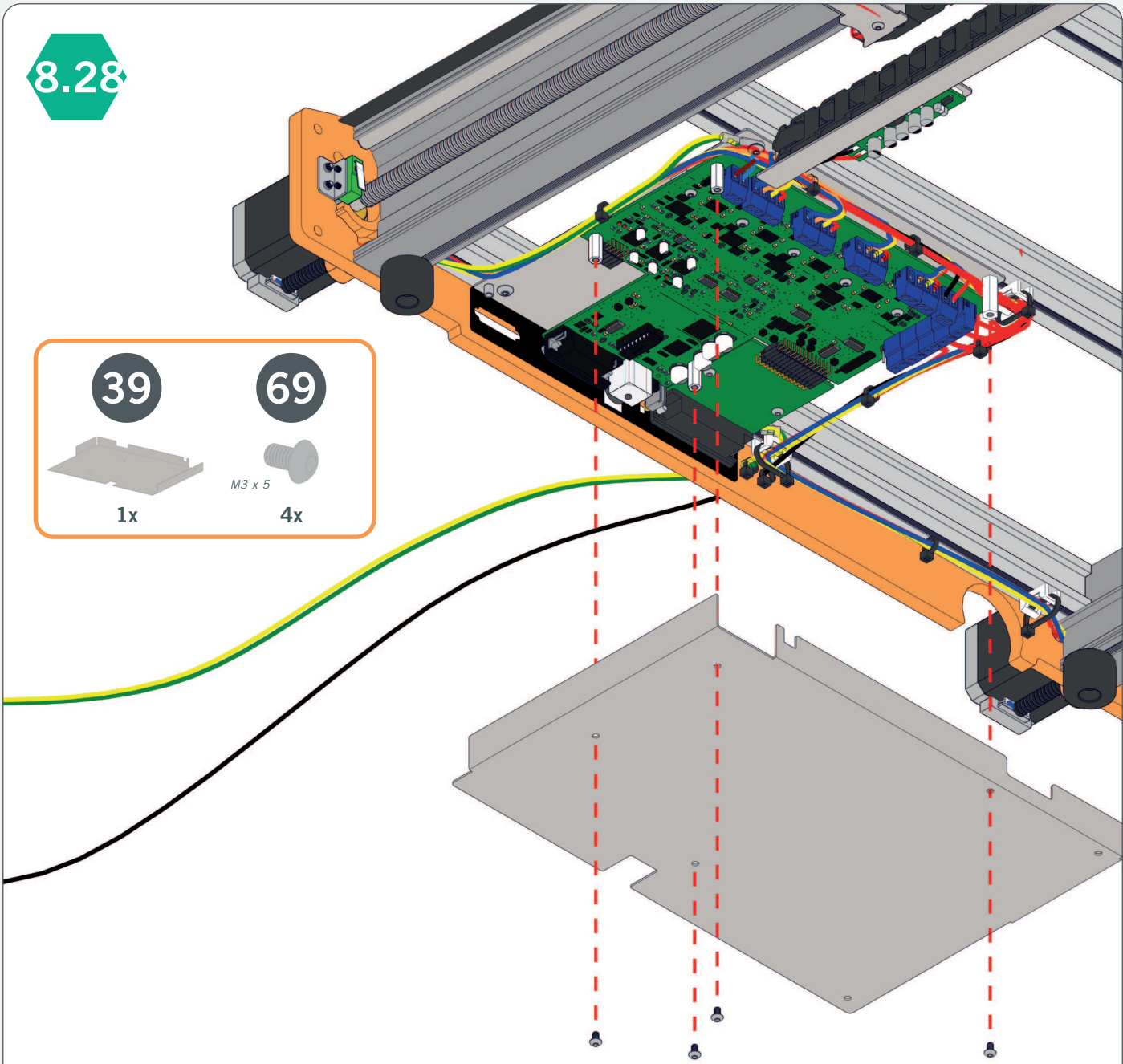

i
Przed przykręceniem sprawdź, czy kable nie są zgniecione!
Before screwing avoid crushing the cables!

10.3

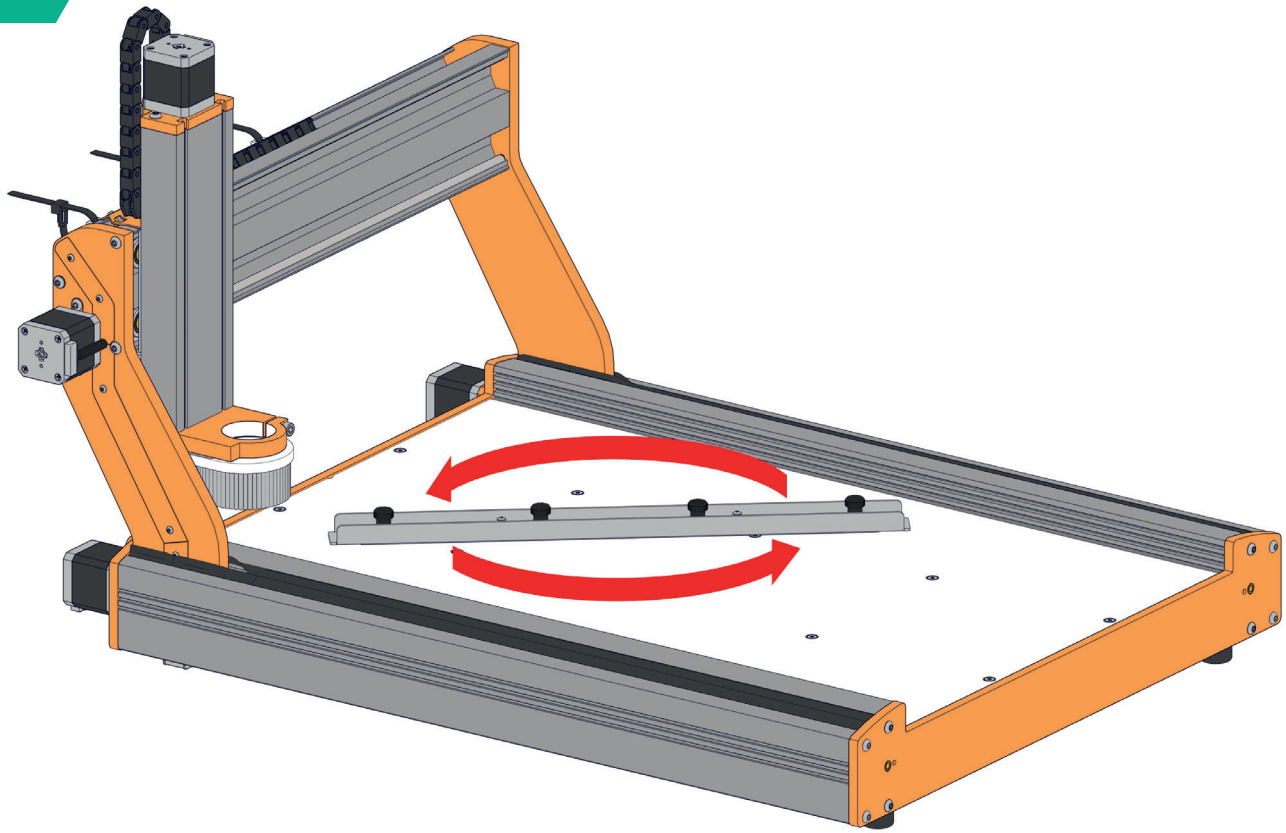

10.4

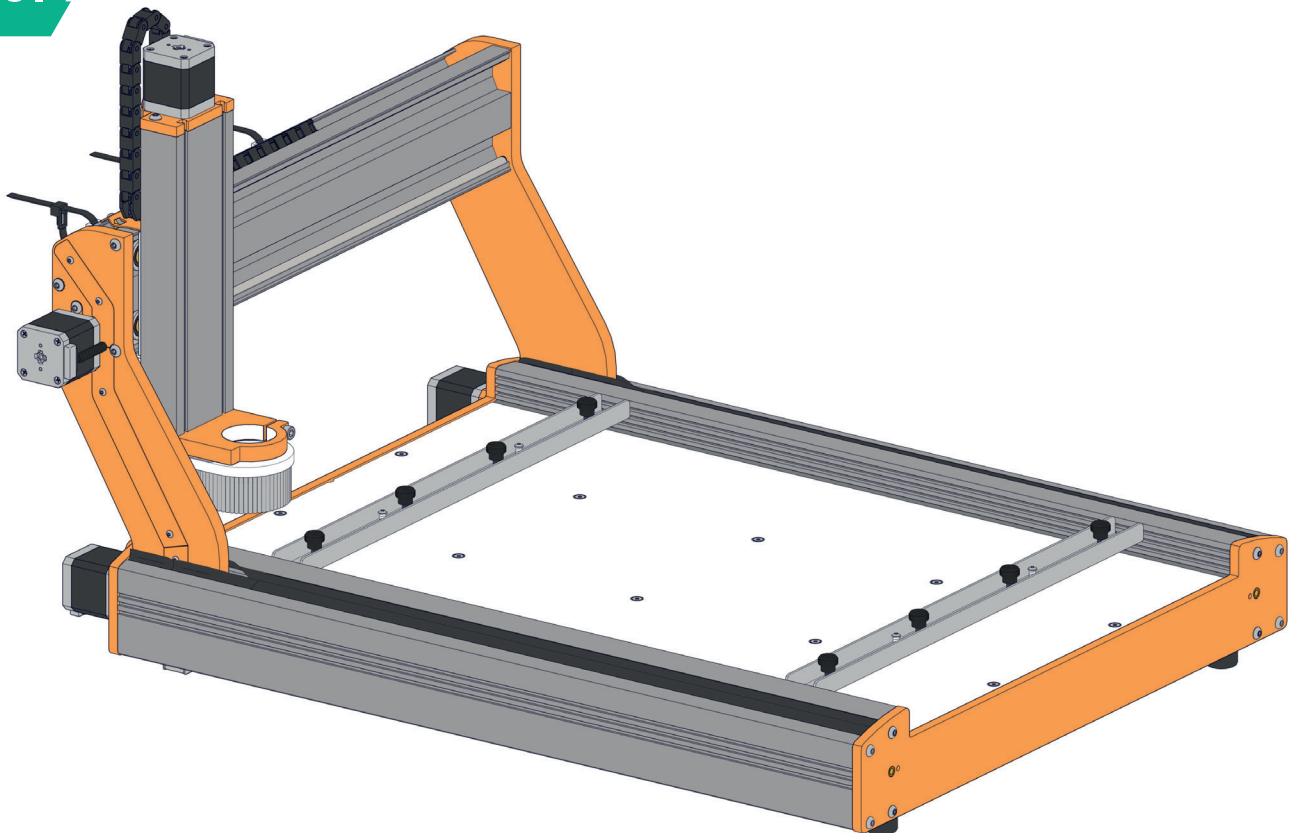



STEPCRAFT GmbH & Co. KG

An der Beile 2
58708 Menden (Sauerland)
Niemcy

tel.: +49 (0) 23 73 / 179 11 60
mail: info@stepcraft-systems.com
net: www.stepcraft-systems.com

STEPCRAFT Inc.

151 Field Street
06790 Torrington, CT
United States

tel.: +1 (203) 5 56 18 56
mail: info@stepcraft.us
net: www.stepcraft.us